

# DRIVE THE CHANGE



BR.2017.01.0085.01.02

**CORMIDI**

**C85**  
MINI TRACK DUMPER



## MASSIMA EFFICIENZA



Tantissime ore di collaudo e minuziose ottimizzazioni di tutti i particolari hanno fatto sì che la C85 è in assoluto la macchina più performante ed affidabile della sua categoria, l'obiettivo è quello di una macchina durevole nel tempo con costi di manutenzione ridotti a zero.

## SOTTOCARRO



Il sottocarro progettato in ogni minimo dettaglio per la C85 è frutto delle esperienze del Team Sviluppo della Cormidi, esperienza e competenza hanno portato alla realizzazione di un sottocarro senza eguali.

## SEMPLICEMENTE INCREDIBILE



Il CDL centro stile della Cormidi ha creato una macchina dalle linee morbide ed sinuose bella da guardare, ma allo stesso tempo solida, concreta ed ergonomica.

**CORMIDI**

**C85**  
MINI TRACK DUMPER



DRIVE THE CHANGE

# PUNTI DI FORZA



# PUNTI DI FORZA



Radiocomando per lavori difficili e pericolosi.



Paraurti di protezione cofano motore.



Sistema di regolazione giri motore con cavi senza manutenzione.



Collegare accessori ausiliari come trencher, trivelle, non è stato mai così semplice.



Un cicalino sonoro si attiva in caso di necessità; ad esempio, quando il quadro è acceso e l'operatore non avvia il motore. Il contatore inoltre permette di contare la vita della macchina.



Freno di parcheggio ed emergenza meccanico.



Ganci per sollevare la macchina in modo sicuro.



I rulli oscillanti adattano i cingoli a tutti i tipi di fondo in modo da garantire sempre un'ottima aderenza alla macchina e soprattutto grande stabilità su sterrati particolarmente ardui.



In situazioni dove è necessario avere una macchina più corta e possibile richiudere la pedana, oppure al contrario, mantenerla aperta per ospitare l'operatore.

# CORMIDI

# CBS

MINI TRACK DUMPER



# DUMPER

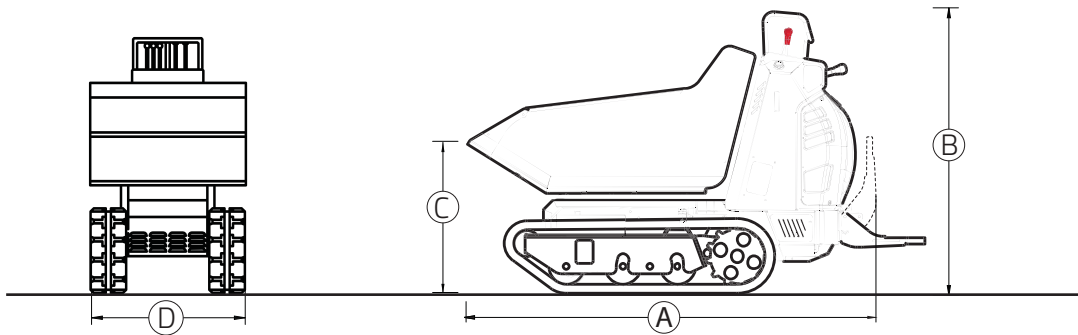

	mm	inch.
A	1926	A 75.8
B	1336	B 52.6
C	739	C 29.1
D	810	D 31.9

	C10.85	C13.85	C14.85
CAPACITA' OPERATIVA	800 kg 1764 Lb	800 kg 1764 Lb	800 kg 1764 Lb
PESO TOTALE	566 kg 1248 Lb	541 kg 1193 Lb	588 kg 1296 Lb
RASO	0,28 m <sup>3</sup> 0.33 yd <sup>3</sup>	0,28 m <sup>3</sup> 0.33 yd <sup>3</sup>	0,28 m <sup>3</sup> 0.33 yd <sup>3</sup>
COLMO SAE	0,36 m <sup>3</sup> 0.45 yd <sup>3</sup>	0,36 m <sup>3</sup> 0.45 yd <sup>3</sup>	0,36 m <sup>3</sup> 0.45 yd <sup>3</sup>

# CORMIDI

# CBS

MINI TRACK DUMPER



DRIVE THE CHANGE

# AUTOCARICANTE

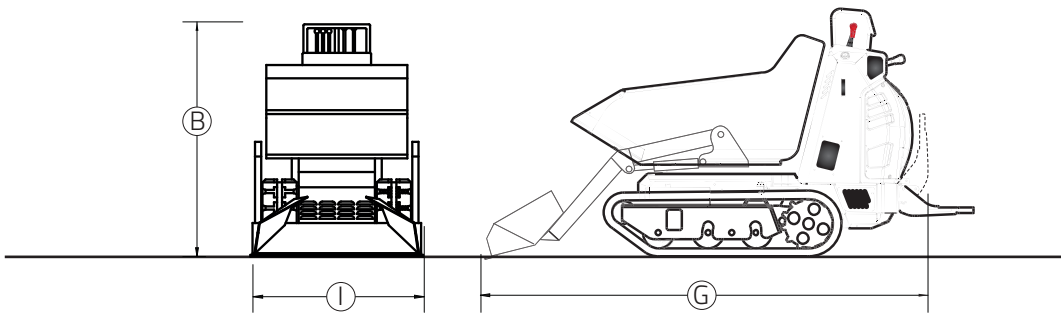

	mm	inch.
B	1336	B 52.6
G	2595	G 102.2
I	835	I 32.9
H	1500	H 59.1

	C10.85	C13.85	C14.85
CAPACITA' OPERATIVA	800 kg 1764 Lb	800 kg 1764 Lb	800 kg 1764 Lb
PESO TOTALE	662 kg 1460 Lb	637 kg 1404 Lb	684 kg 1508 Lb
RASO	0,25 m <sup>3</sup> 0.33 yd <sup>3</sup>	0,25 m <sup>3</sup> 0.33 yd <sup>3</sup>	0,25 m <sup>3</sup> 0.33 yd <sup>3</sup>
COLMO SAE	0,34 m <sup>3</sup> 0.45 yd <sup>3</sup>	0,34 m <sup>3</sup> 0.45 yd <sup>3</sup>	0,34 m <sup>3</sup> 0.45 yd <sup>3</sup>

# CORMIDI

# CBS

MINI TRACK DUMPER



DRIVE THE CHANGE

# HI-TIP

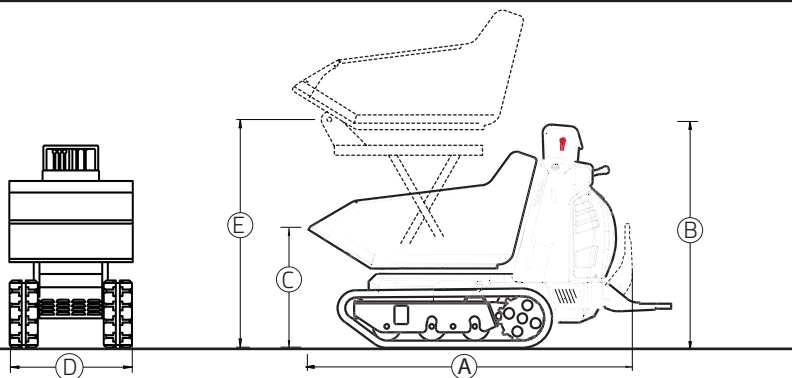

	mm	inch.
A	1926	A 75.8
B	1336	B 52.6
C	739	C 29.1
D	810	D 31.9
E	1500	E 59.1

	C10.85	C13.85	C14.85
CAPACITA' OPERATIVA	800 kg 1764 Lb	800 kg 1764 Lb	800 kg 1764 Lb
PESO TOTALE	668 kg 1472.7 Lb	643 kg 1418 Lb	690 kg 1521 Lb
RASO	0,28 m <sup>3</sup> 0.33 yd <sup>3</sup>	0,28 m <sup>3</sup> 0.33 yd <sup>3</sup>	0,28 m <sup>3</sup> 0.33 yd <sup>3</sup>
COLMO SAE	0,36 m <sup>3</sup> 0.45 yd <sup>3</sup>	0,36 m <sup>3</sup> 0.45 yd <sup>3</sup>	0,36 m <sup>3</sup> 0.45 yd <sup>3</sup>

# CORMIDI

# CBS

MINI TRACK DUMPER



DRIVE THE CHANGE

# HI-TIP E AUTOCARICANTE

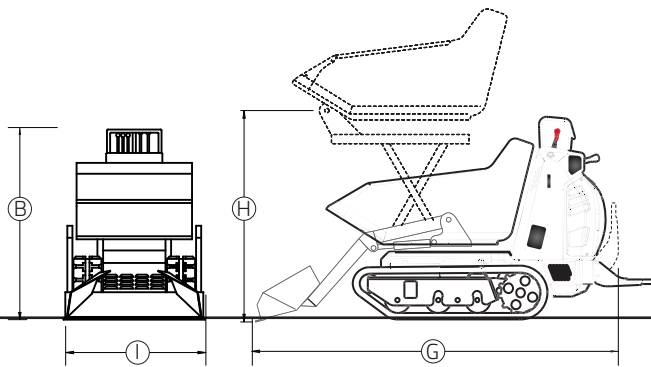

	mm	inch.
B	1336	B 52.6
G	2595	G 102.2
I	835	I 32.9
H	1500	H 59.1

	C10.85	C13.85	C14.85
CAPACITA' OPERATIVA	800 kg 1764 Lb	800 kg 1764 Lb	800 kg 1764 Lb
PESO TOTALE	765 kg 1687 Lb	740 kg 1631 Lb	787 kg 1735 Lb
RASO	0,25 m <sup>3</sup> 0.33 yd <sup>3</sup>	0,25 m <sup>3</sup> 0.33 yd <sup>3</sup>	0,25 m <sup>3</sup> 0.33 yd <sup>3</sup>
COLMO SAE	0,34 m <sup>3</sup> 0.45 yd <sup>3</sup>	0,34 m <sup>3</sup> 0.45 yd <sup>3</sup>	0,34 m <sup>3</sup> 0.45 yd <sup>3</sup>

## CORMIDI

## CBS

MINI TRACK DUMPER



DRIVE THE CHANGE



# BETONIERA

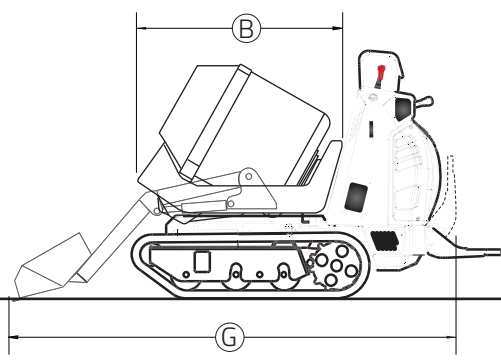
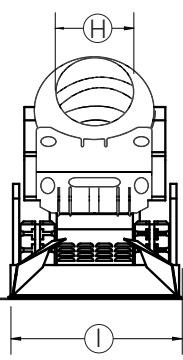

	mm	inch.
B	1125	B 44.3
G	2595	G 102.2
I	835	I 32.9
H	425	H 16.7

	C10.85	C13.85	C14.85
CAPACITA' OPERATIVA	800 kg 1764 Lb	800 kg 1764 Lb	800 kg 1764 Lb
PESO TOTALE			
RASO	240 L 63.4 gal	240 L 63.4 gal	240 L 63.4 gal
COLMO SAE	130 L 34.3 gal	130 L 34.3 gal	130 L 34.3 gal

**CORMIDI**

**CBS**  
MINI TRACK DUMPER



# MINI CARICATORE

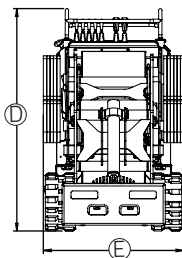
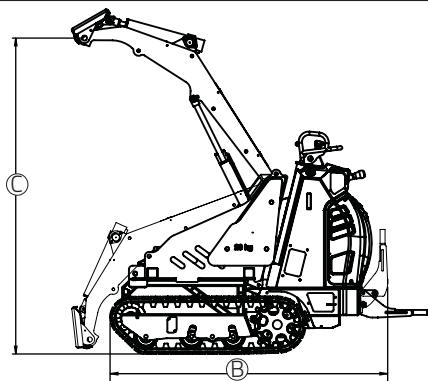

	mm	inch.
B	1654	B 65.1
C	1884	C 74.2
D	1326	D 52.2
E	837	E 33.0

	C10.85	C13.85	C14.85
CAPACITA' OPERATIVA	800 kg 1764 Lb	800 kg 1764 Lb	800 kg 1764 Lb
PESO TOTALE	800 kg 1764 Lb	800 kg 1764 Lb	800 kg 1764 Lb
CON CONTRAPPESO 160 KG CON OPERATORE	312 kg 687.8 Lb	CON CONTRAPPESO 160 KG SENZA OPERATORE	248 kg 546.8 Lb
SENZA CONTRAPPESO CON OPERATORE	259 kg 571 Lb	SENZA CONTRAPPESO SENZA OPERATORE	195 kg 429.9 Lb

## CORMIDI













## CBS

MINI TRACK DUMPER

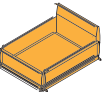

DRIVE THE CHANGE

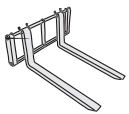
# ACCESSORI

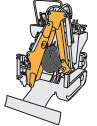
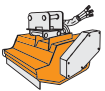
		C10.85	C13.85	C14.85	
trivella 		RI-RIA AC-ACW HI HIAC HIACW	<input type="checkbox"/>	<input type="checkbox"/>	<input type="checkbox"/>
sega idraulica 	trencher 	RI-RIA AC-ACW HI HIAC HIACW	<input type="checkbox"/>	<input type="checkbox"/>	<input type="checkbox"/>
pompa acqua 		RI-RIA AC-ACW HI HIAC HIACW	<input type="checkbox"/>	<input type="checkbox"/>	<input type="checkbox"/>
martello idr. 	martello idr. 	RI-RIA AC-ACW HI HIAC HIACW	<input type="checkbox"/>	<input type="checkbox"/>	<input type="checkbox"/>
radiocomando 		RI-RIA AC-ACW HI HIAC HIACW	<input type="checkbox"/>	<input type="checkbox"/>	<input type="checkbox"/>
cassone agri 		RIA	<input type="checkbox"/>	<input type="checkbox"/>	<input type="checkbox"/>
Atomizzatore 		RIA	<input type="checkbox"/>	<input type="checkbox"/>	<input type="checkbox"/>
spazzatrice 	spazzola 				
forche 		ACW	<input type="checkbox"/>	<input type="checkbox"/>	<input type="checkbox"/>
lama 		ACW	<input type="checkbox"/>	<input type="checkbox"/>	<input type="checkbox"/>
mini escavatore 		ACW	<input type="checkbox"/>	<input type="checkbox"/>	<input type="checkbox"/>
trinciasarmenti 		ACW	<input type="checkbox"/>	<input type="checkbox"/>	<input type="checkbox"/>

SPECIFICHE		METRIC	U.S.	13.85	10.85	14.85	ELECTRICA
<b>MOTORE</b>							
Benzina	Honda Gx 390 13 hp			●			
Diesel	Yanmar LN 100 AE 10 hp				●		
Diesel	Kubota Z 482 14 hp					●	
Elettrica	6 hp						●
<b>TRASMISSIONE</b>							
Tipo	Idrostatica			●	●	●	●
Pompe idrauliche	2 pompe a pistoni a portata variabile			●	●	●	●
<b>SOTTOCARRO</b>							
Larghezza dei cingoli	180 mm	(7.1 in)					
Rulli oscillanti	Sì			●	●	●	●
<b>IMPIANTO IDRAULICO</b>							
Pompe idrauliche	Pompe ad ingranaggi						
Flusso Std	1x15,2 l/min	(1x4.0 gpm)	●				●
	1x13,4 l/min	(1x3.5 gpm)		●	●		
Alto flusso	1x20,8 l/min	(1x5.5 gpm)	●				●
	1x18,5 l/min	(1x4.8 gpm)		●	●		
Super Alto Flusso	1x25,6 l/min	(1x6.7 gpm)				●	
Pressione massima	150 bar	(2180 psi)	●	●	●	●	●
<b>PRESTAZIONI E DIMENSIONI</b>							
Velocità massima	(5 Km/h)	(3.1 mph)	●				
	(6 Km/h)	(3.7 mph)		●			●
Capacità operativa	800 kg	(1762 LB)	●	●	●	●	●
Peso	560 to/a 690 kg	(1235 to/a 1521)	●				
	540 to/a 750 kg	(1191 to/a 1654)		●			
Capacità del cassone	0.28 m <sup>3</sup>	(0.37 yd <sup>3</sup> )	●	●	●	●	●
	0.45 m <sup>3</sup>	(0.59 yd <sup>3</sup> )					
Freno di stazionamento	Sì			●	●	●	●